

Last Modified: 6-2-2008	5.1 G	From: 200601
Model Year: 2007	Model: Camry	Doc ID: RM0000027RU000X
Title: 2GR-FE ENGINE MECHANICAL: ENGINE ASSEMBLY: INSPECTION (2007 Camry)		

INSPECTION

1. INSPECT EXHAUST MANIFOLD SUB-ASSEMBLY LH

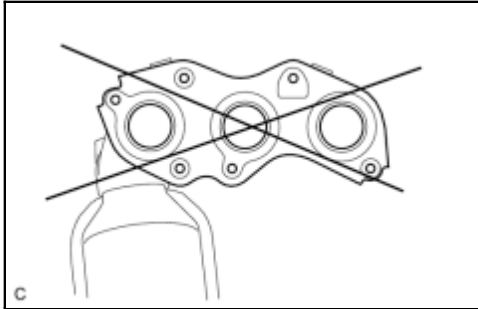

- (a) Using a precision straightedge and feeler gauge, measure the warpage on the contact surface of the cylinder head.

Maximum warpage:
0.7 mm (0.028 in.)

The maximum allowable warpage of each installation surface is 0.3 mm (0.012 in.).

If the warpage is greater than the maximum, replace the manifold.

2. INSPECT EXHAUST MANIFOLD SUB-ASSEMBLY RH

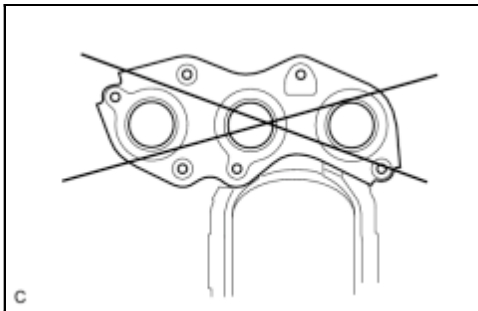

- (a) Using a precision straightedge and feeler gauge, measure the warpage on the contact surface of the cylinder head.

Maximum warpage:
0.7 mm (0.028 in.)

The maximum allowable warpage of each installation surface is 0.3 mm (0.012 in.).

If the warpage is greater than the maximum, replace the manifold.

3. INSPECT INTAKE AIR SURGE TANK ASSEMBLY

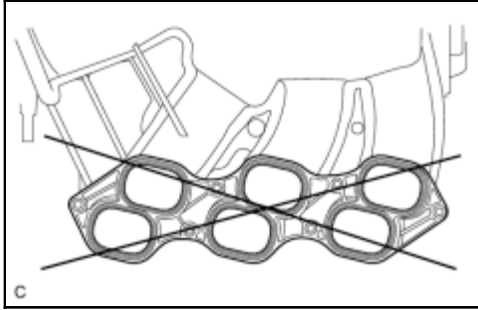

- (a) Using a precision straightedge and feeler gauge, measure the warpage on the contact surface of the intake manifold.

Maximum warpage:

2.5 mm (0.098 in.)

If the warpage is greater than the maximum, replace the surge tank.

