

Last Modified: 6-2-2008	5.1 C	From: 200601
Model Year: 2007	Model: Camry	Doc ID: RM000000PF400OX
Title: 2GR-FE ENGINE CONTROL SYSTEM: SFI SYSTEM: P0101: Mass Air Flow Circuit Range / Performance Problem (2007 Camry)		

DTC	P0101	Mass Air Flow Circuit Range / Performance Problem
------------	--------------	--

DESCRIPTION

The Mass Air Flow (MAF) meter is a sensor that measures the amount of air flowing through the valve.

The ECM uses this information to determine the fuel injection time and to provide appropriate air-fuel ratio.

Inside the MAF meter, there is a heated platinum wire which is exposed to the flow of intake air.

By applying a specific electrical current to the wire, the ECM heats it to a given temperature. The flow of incoming air cools both the wire and an internal thermistor, affecting their resistance. To maintain a constant current value, the ECM varies the voltage applied to these components in the MAF meter. The voltage level is proportional to the airflow through the sensor, and the ECM uses it to calculate the intake air volume.

The circuit is constructed so that the platinum hot wire and the temperature sensor provide a bridge circuit, and the power transistor is controlled so that the potentials of A and B remain equal to maintain the predetermined temperature.

When any of these DTCs are set, the ECM enters fail-safe mode. During fail-safe mode, the ignition timing is calculated by the ECM, according to the engine RPM and throttle valve position. Fail-safe mode continues until a pass condition is detected.

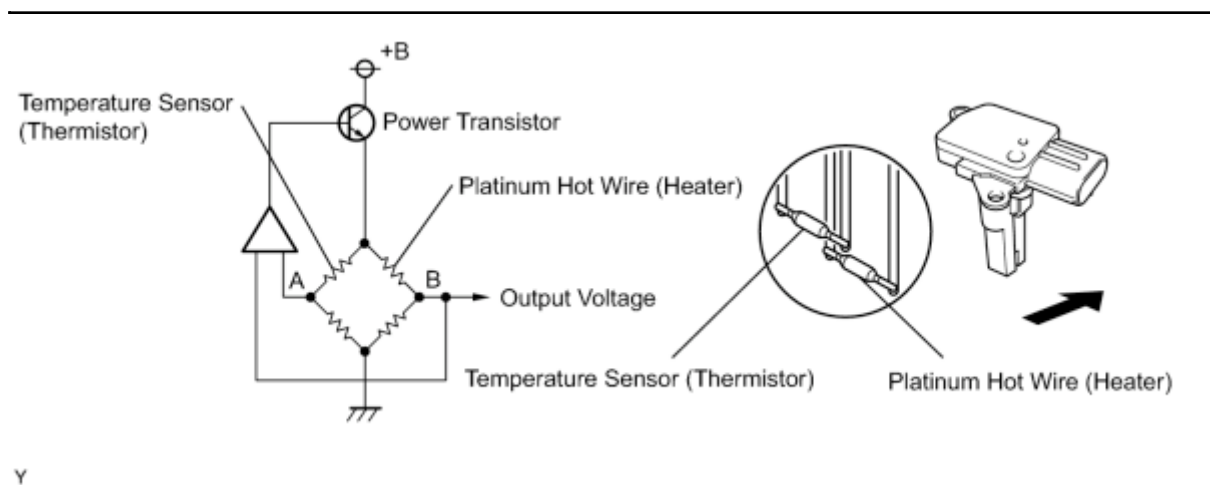

DTC NO.	DTC DETECTION CONDITION	TROUBLE AREA
------------	-------------------------	-----------------

