

<b>Last Modified:</b> 6-2-2008	5.1 G	<b>From:</b> 200601
<b>Model Year:</b> 2007	<b>Model:</b> Camry	<b>Doc ID:</b> RM000002D4B000X
<b>Title:</b> 2GR-FE ENGINE CONTROL SYSTEM: IGNITION RELAY NO. 2: INSPECTION (2007 Camry)		

## INSPECTION

### 1. INSPECT IGNITION RELAY NO. 2

(a) Using an ohmmeter, measure the resistance according to the value(s) in the table below.

Standard resistance:

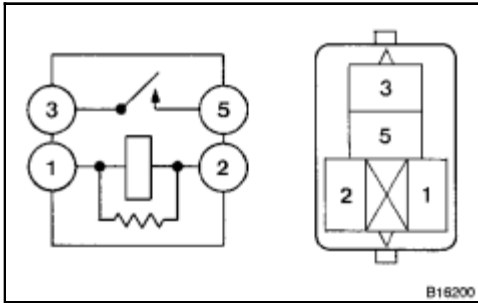

TESTER CONNECTION	SPECIFIED CONDITION
3 - 5	10 k $\Omega$ or higher
3 - 5	Below 1 $\Omega$ (Battery voltage applied between terminals 1 and 2)

If the result is not as specified, replace the relay.

