

ECT and A/T Indicator for 1MZ-FE and 3MZ-FE

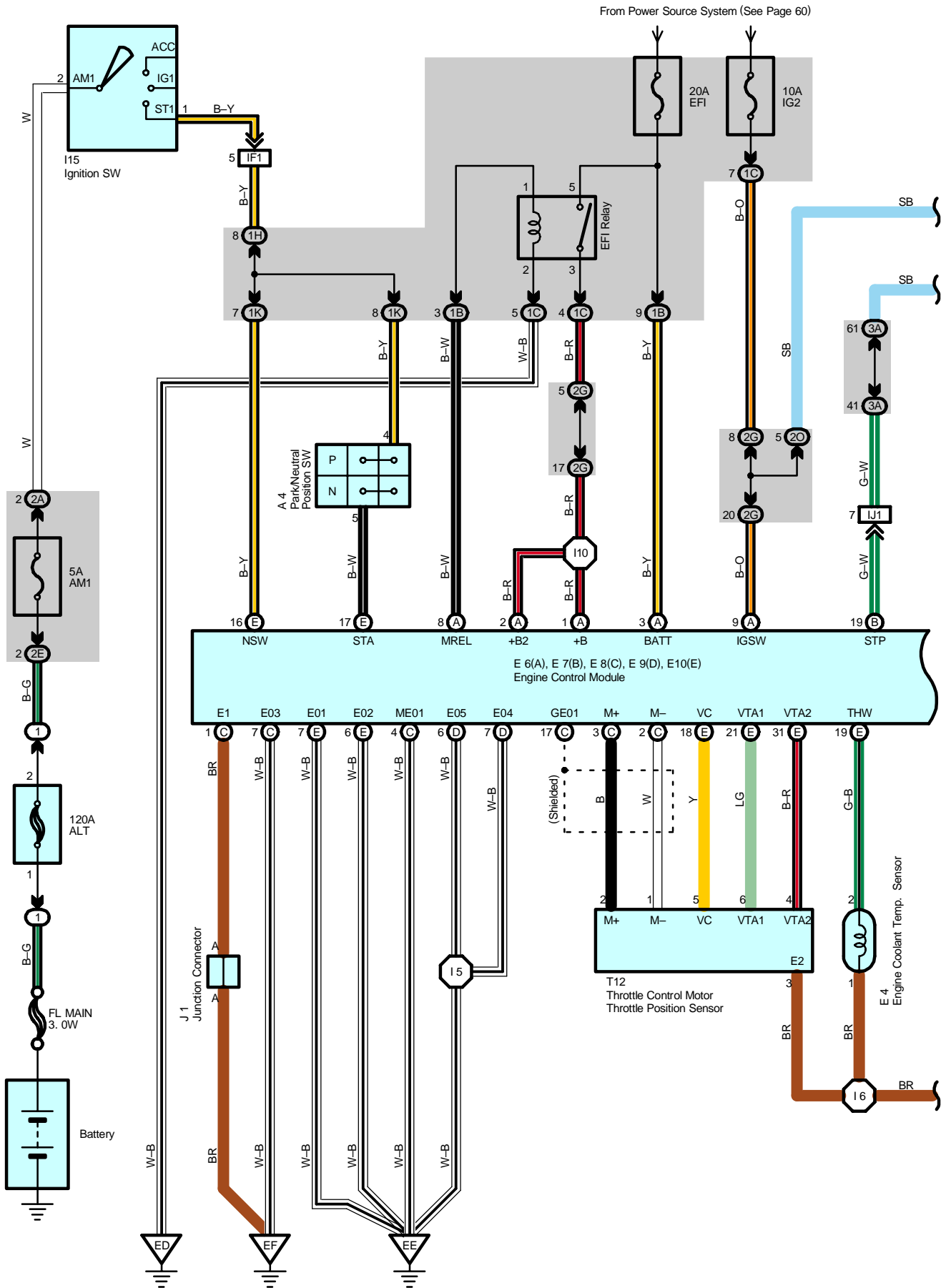

From Power Source System (See Page 60)

* 1 : TMC Made
 * 2 : TMMK Made

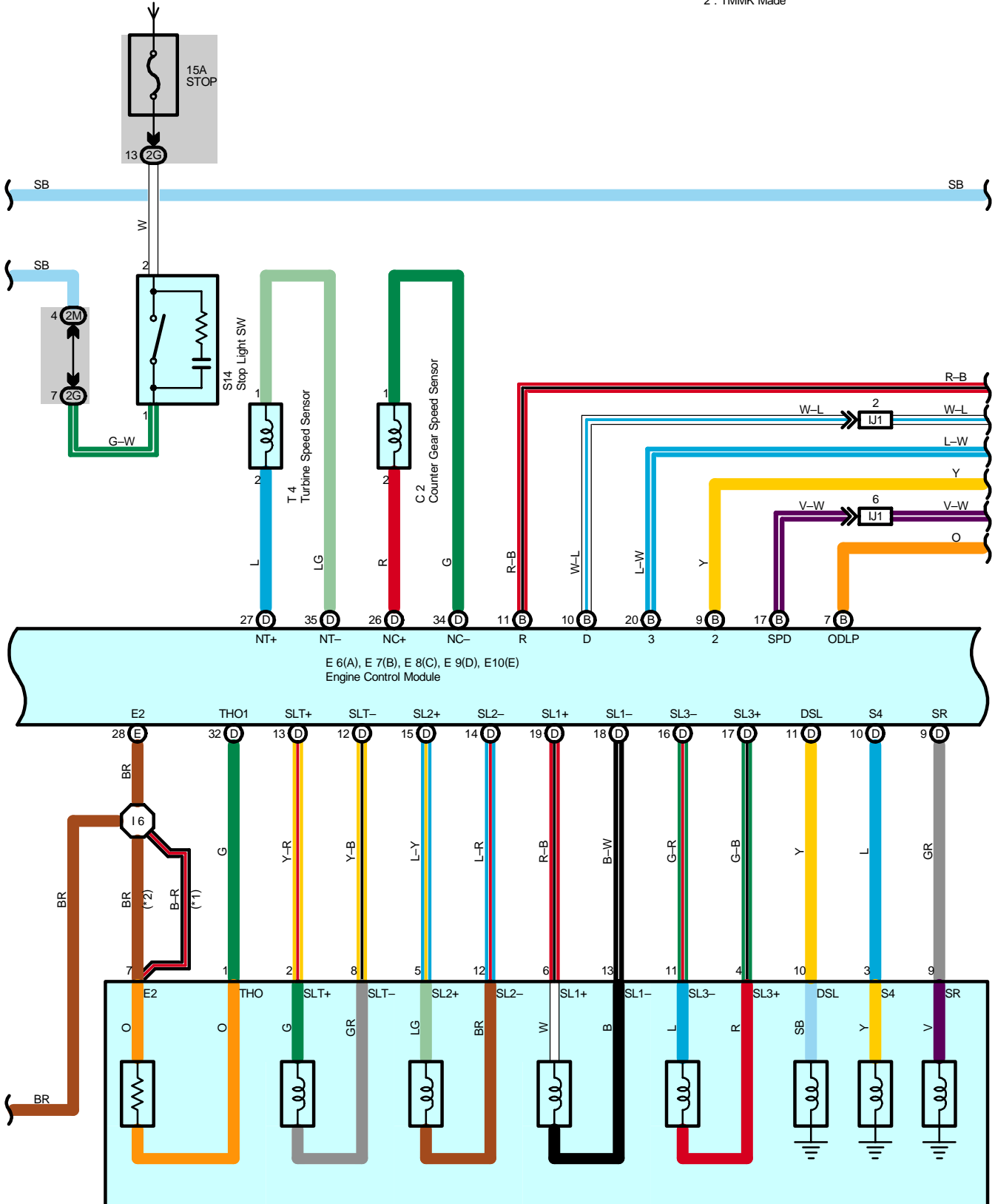

E 3
 Electronically Controlled Transmission Solenoid

ECT and A/T Indicator for 1MZ-FE and 3MZ-FE

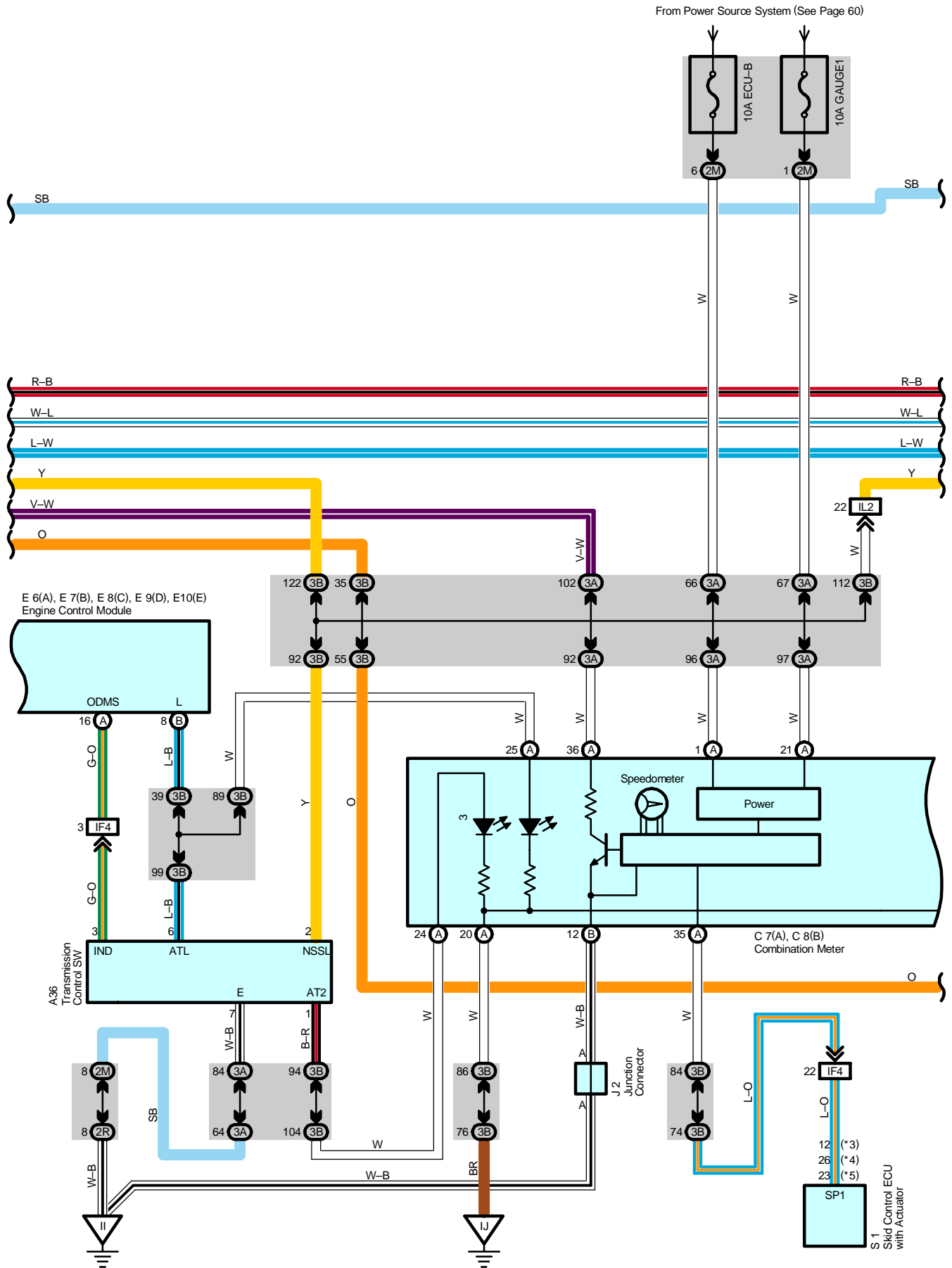

From Power Source System (See Page 60)

- * 3 : w/ VSC
- * 4 : w/o VSC TMC Made
- * 5 : w/o VSC TMMK Made

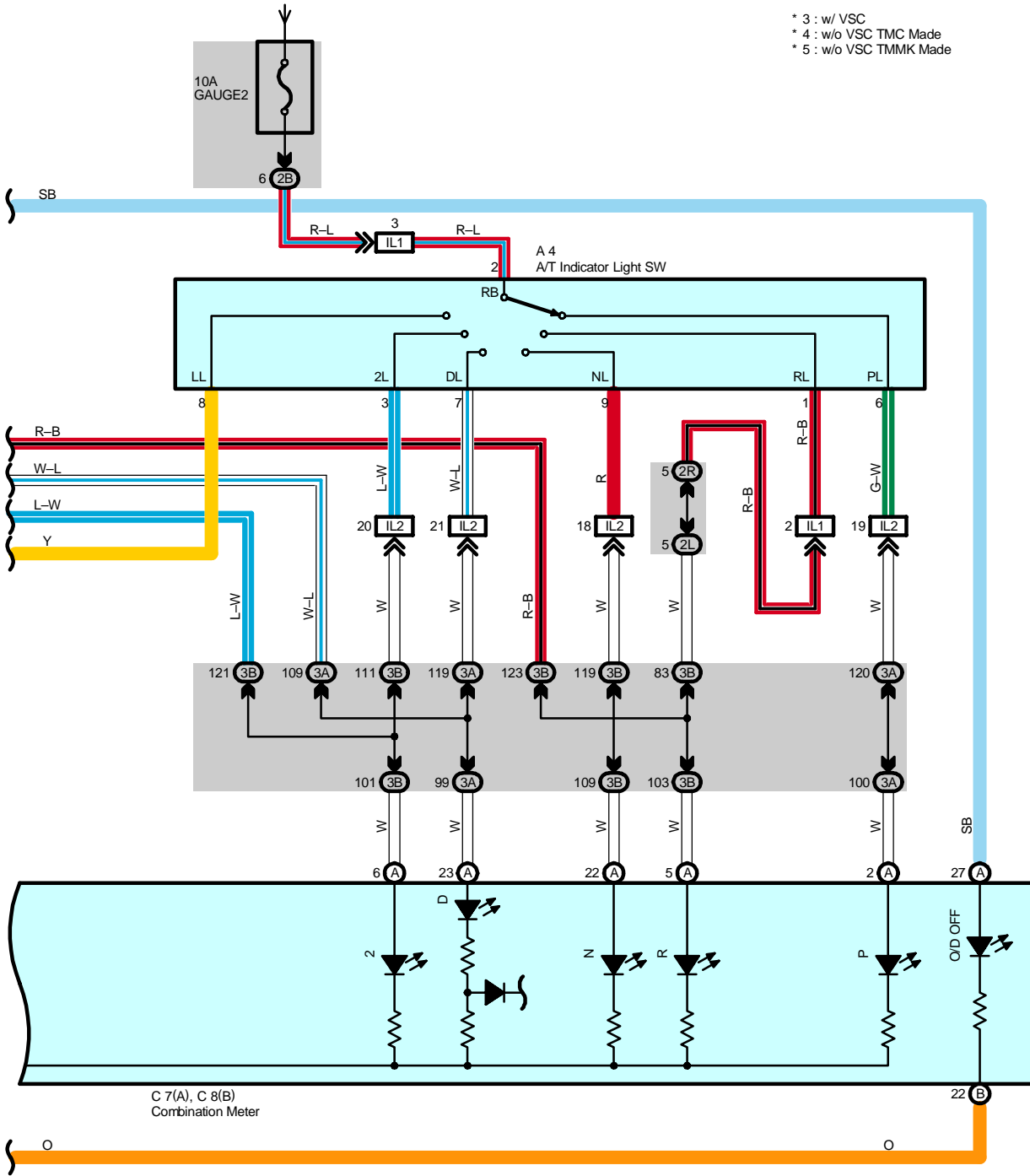

ECT and A/T Indicator for 1MZ-FE and 3MZ-FE

System Outline

Previous automatic transaxle have selected each gear shift using mechanically controlled throttle hydraulic pressure, governor hydraulic pressure and lock-up hydraulic pressure. The electronically controlled transmission, however, electrically controls the line pressure, throttle pressure, lock-up pressure and accumulator pressure etc. through the solenoid valve. The electronically controlled transmission is a system which precisely controls gear shift timing and lock-up timing in response to the vehicle's driving conditions and the engine condition detected by various sensors. It makes smooth driving possible by shift selection for each gear which is the most appropriate to the driving conditions at that time, and by preventing downing, squat and gear shift shock when starting off.

1. Gear Shift Operation

When driving, the engine warm up condition is input as a signal to TERMINAL THW of the engine control module from the engine coolant temp. sensor and the vehicle speed signal is input to TERMINAL SPD of the engine control module. At the same time, the throttle valve opening signal from the throttle position sensor is input to TERMINALS VTA1 and VTA2 of the engine control module as throttle angle signal.

Based on these signals, the engine control module selects the best shift position for the driving conditions and sends current to the electronically controlled transmission solenoid.

2. Lock-Up Operation

When each signal makes engine control module recognize that LOCK-UP condition is satisfied, the current flows from engine control module TERMINAL DSL to electronically controlled transmission solenoid TERMINAL 10. At the same time, the current flows engine control module TERMINAL SL1+ to electronically controlled transmission solenoid TERMINAL 6 and from TERMINAL 13 to engine control module TERMINAL SL1-. This works LOCK-UP solenoid to perform LOCK-UP operation.

3. Stop Light SW Circuit

If the brake pedal is depressed (Stop light SW on) when driving in lock-up condition, a signal is input to TERMINAL STP of the engine control module. The engine control module operates and cuts the current to the solenoid to release lock-up.

4. Overdrive Circuit

* Overdrive on

When the engine is turned on from ignition off, the engine control module turns the O/D on. When the O/D main SW is pushed while the O/D is off, a signal is input into TERMINAL ODMS of the engine control module, and the O/D is turned on by the engine control module. In this case, the engine control module controls the gear shift according to the vehicle's driving condition, using the O/D range. At this time, the O/D off indicator light is off.

* Overdrive off

When the O/D main SW is pushed while the O/D is on, a signal is input into TERMINAL ODMS of the engine control module, and the O/D is turned off. At this time, the current flows through the O/D off indicator light to TERMINAL ODLF of the engine control module. As a result, the O/D off indicator light turns on, and the engine control module controls the gear shift according to the vehicle's driving condition, without using the O/D range.

Service Hints

E6 (A), E7 (B), E8 (C), E9 (D), E10 (E) Engine Control Module

L-E1 : 10.0-14.0 volts (Ignition SW on and shift lever at L position)

2-E1 : 10.0-14.0 volts (Ignition SW on and shift lever at 2 position)

R-E1 : 10.0-14.0 volts (Ignition SW on and shift lever at R position)

D-E1 : 10.0-14.0 volts (Ignition SW on and shift lever at D position)

ODMS-E1 : 10.0-14.0 volts (O/D main SW on)

Below 1.0 volts (O/D main SW off)

THO1-E2 : Below 1.0 volts (Ignition SW on and AFT temperature 110 °C (230 °F))

SLT+ -SLT- : 10.0-14.0 volts (Ignition SW on)

A4 A/T Indicator Light SW

2-6 : Closed with the shift lever in P position

2-1 : Closed with the shift lever in R position

2-9 : Closed with the shift lever in N position

2-7 : Closed with the shift lever in D position

2-8 : Closed with the shift lever in L position

2-3 : Closed with the shift lever in 2 position

 : **Parts Location**

Code	See Page	Code	See Page	Code	See Page		
A4	36 (*1)	E6	A	40	J2	41	
A36	40	E7	B	40	S1	37 (*1)	
C2	36 (*1)	E8	C	40	S14	41	
C7	A	40	E9	D	40	T4	37 (*1)
C8	B	40	E10	E	40	T12	37 (*1)
E3	36 (*1)	I15		41			
E4	36 (*1)	J1		41			

 : **Relay Blocks**

Code	See Page	Relay Blocks (Relay Block Location)
1	22	Engine Room R/B (Engine Compartment Left)

 : **Junction Block and Wire Harness Connector**

Code	See Page	Junction Block and Wire Harness (Connector Location)
1B	25	Engine Room Main Wire and Engine Room J/B (Engine Compartment Left)
1C		
1H		
1K	25	Engine Wire and Engine Room J/B (Engine Compartment Left)
2A	28	Instrument Panel Wire and Driver Side J/B (Lower Finish Panel)
2B		
2E	28	Engine Room Main Wire and Driver Side J/B (Lower Finish Panel)
2G		
2L	29	Instrument Panel Wire and Driver Side J/B (Lower Finish Panel)
2M		
2O		
2R		
3A	34	Instrument Panel Wire and Passenger Side J/B (Instrument Panel Brace RH)
3B		

 : **Connector Joining Wire Harness and Wire Harness**

Code	See Page	Joining Wire Harness and Wire Harness (Connector Location)
IF1	50	Engine Room Main Wire and Instrument Panel Wire (Right Side of Steering Column Tube)
IF4		
IJ1	52	Instrument Panel Wire and Instrument Panel Wire (Instrument Panel Reinforcement RH)
IL1	52	Engine Wire and Instrument Panel Wire (Behind the Glove Box)
IL2		

 : **Ground Points**

Code	See Page	Ground Points Location
ED	46 (*1)	Left Fender
EE	46 (*1)	Left Side of Cylinder Head
EF	46 (*1)	Right Side of Cylinder Head
II	50	Cowl Side Panel LH
IJ	50	Instrument Panel Brace LH

 : **Splice Points**

Code	See Page	Wire Harness with Splice Points	Code	See Page	Wire Harness with Splice Points
I5	52	Engine Wire	I10	52	Engine Room Main Wire
I6					

* 1 : 1MZ-FE, 3MZ-FE * 2 : 2AZ-FE * 3 : w/ Power Seat * 4 : w/o Power Seat